

BEFORE AMP IMPROVEMENT

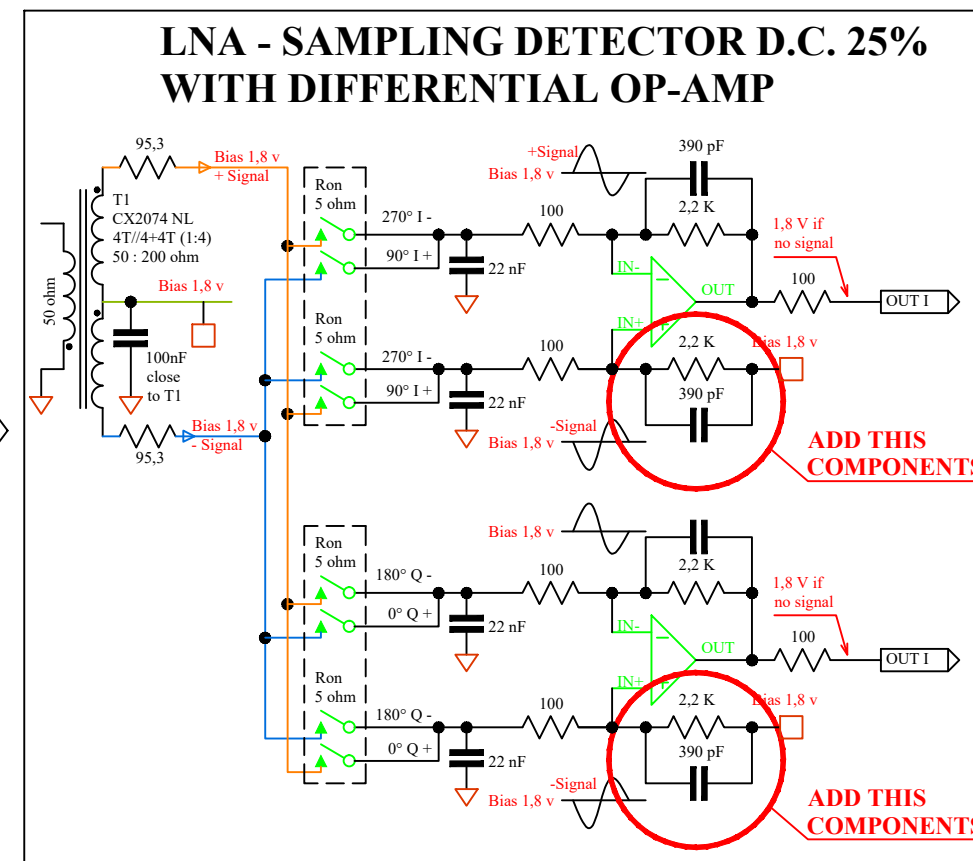

AFTER AMP IMPROVEMENT